

2 Gang 250W Multi-Way Intelligent Dimmer - Traditional Plate

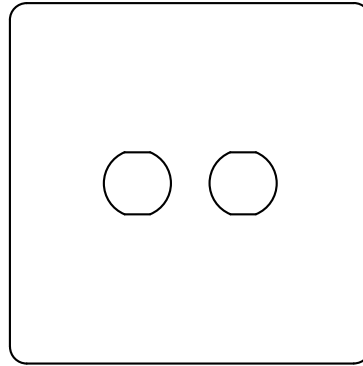

20-GRD133

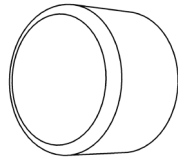

SGP146

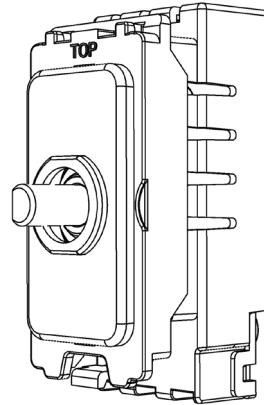

Enkin PDM250 & SOHO Grid Adapter

Contents

20-GRD133	2 Gang Circular Hole Grid Plate - Traditional
	— 20-PLT133 2 Gang Circular Hole Traditional Grid Plate
	— 20-EDG007 Single Traditional Type Gasket
	— SGPYLK-12 Single Grid Frame (Yoke)
SGP146	CM-Grid Dimmer Knob X 2
Enkin PDM250	250W Multi-Way Intelligent Dimmer with Soho CM Grid Adapter X 2

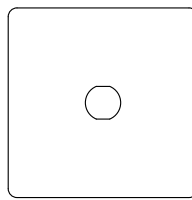

20-GRD132

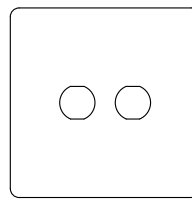

20-GRD133

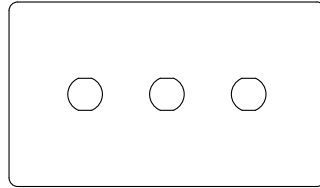

20-GRD135

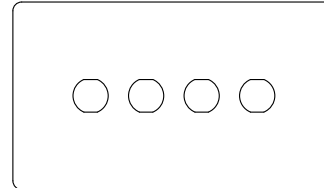

20-GRD136

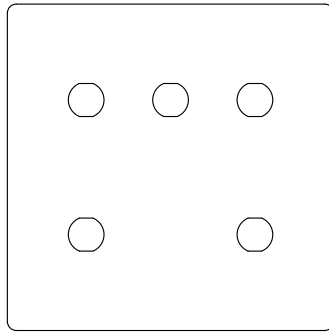

20-GRD137

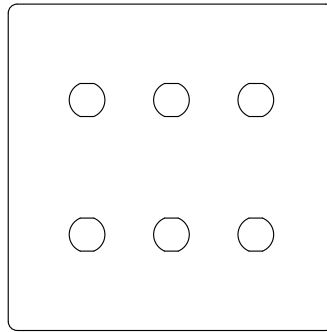

20-GRD138

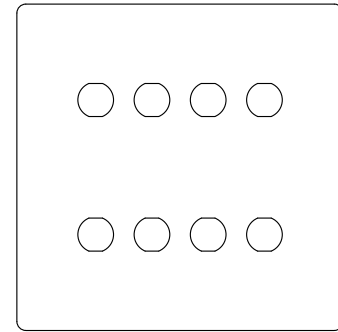

20-GRD139

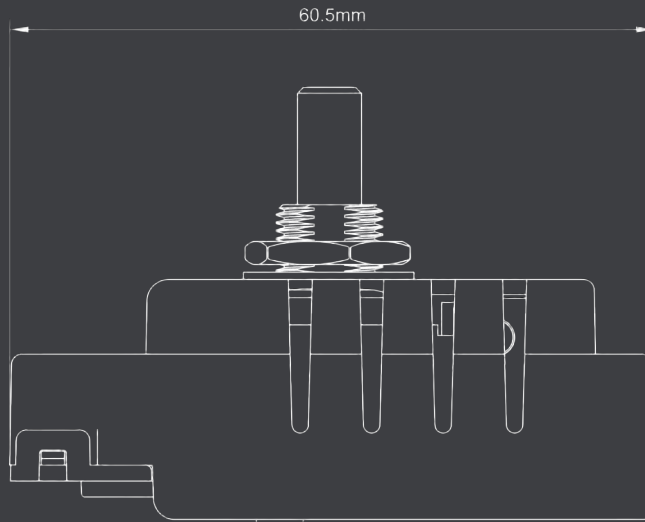
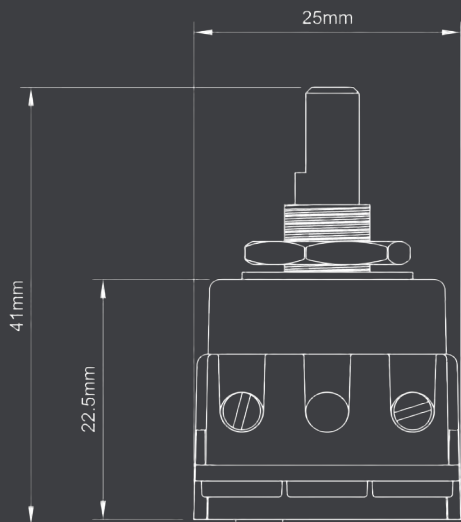

TECHNICAL SPECIFICATION

Standard(s)	BS 5733 (Where Applicable)
Mounting Box Depth (Recommended)	47mm
Earth Terminal Capacity	3 x 2.5mm ² , 2 x 4.0mm ² , 1 x 6.0mm ² (EARTH)
Fixing Centres	60.3mm (Single width) 120.6mm (Double Width)
Size - (1 Gang) 20-GRD132	86mm x 86mm x 4.5mm (Plate Thickness Inc. Gasket)
Size - (2 Gang) 20-GRD133	86mm x 86mm x 4.5mm (Plate Thickness Inc. Gasket)
Size - (3 Gang) 20-GRD135	86mm x 146mm x 4.5mm (Plate Thickness Inc. Gasket)
Size - (4 Gang) 20-GRD136	86mm x 146mm x 4.5mm (Plate Thickness Inc. Gasket)
Size - (5 Gang) 20-GRD137	146mm x 146mm x 4.5mm (Plate Thickness Inc. Gasket)
Size - (6 Gang) 20-GRD138	146mm x 146mm x 4.5mm (Plate Thickness Inc. Gasket)
Size - (8 Gang) 20-GRD139	146mm x 146mm x 4.5mm (Plate Thickness Inc. Gasket)
Product Class 1	Face plate must be earthed
Ambient Operating Temperature	-5° to +40°C
Recommended Location	Internal Use Only
Maximum Installation Altitude	2000m
IP Rating	IP2XD



Markings & Standard(s)	CE, UKCA, BS EN 60669-2-1
Operating Voltage	220-240V AC
Main Frequency	50Hz
Minimum Load	2W LED (2W Incandescent/Halogen)
Maximum Load	250W LED (250W Incandescent/Halogen)
Switch Type	Multi-way
Dimming Protocol	Trailing edge phase control
Mounting Box Depth (Min)	35mm
Terminal Capacity	1 x 4mm ² / 1 x 2.5mm ² / 3 x 1.5mm ² / 4 x 1mm ²
Terminal Markings	C (Live), L (Load)
Neutral Required	No
Short Circuit Protection	Yes
Overload/Overcurrent Protection	Yes
Thermal Protection	Yes - Thermal resettable fuse
Soft Start	Yes
Power Failure	Previous state recall
Memory	Non volatile
Min/Max Level Setting	Yes - Following a defined procedure
Driving Mode	Trailing Edge (TE) only
Product Dimensions	60.5mm x 14mm x 25mm
Climate Range	0°C to 40°C, humidity 0% to 95% non-condensing
Recommended Location	Indoor use only
Maximum Installation Altitude	2000m
IP Rating	IP2XD

Operating Voltage	240V ac
Nominal Operating Frequency	50 Hz
Dimming Technique	Trailing edge phase control
Compliance	BS EN 60669-2-1

Load Symbol	Compatible Loads	Max Load	Min Load
	Dimmable LED lighting	250W	2W
	240V Incandescent & Halogen lamps	250W	2W
	Low voltage lighting with electronic transformers	250W	2W

Multi-Gang Switch De-Rating Chart				
1 Gang	2 Gang	3 Gang	4 Gang	5 Gang
250W	212.5W	175W	137.5W	100W

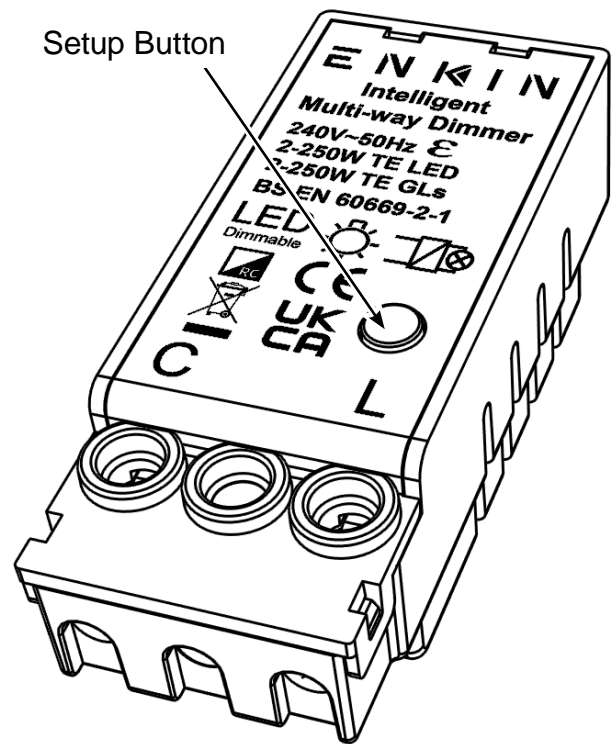

WIRING EXAMPLES

WIRING DIAGRAM - SINGLE PDM250 DIMMER SWITCH

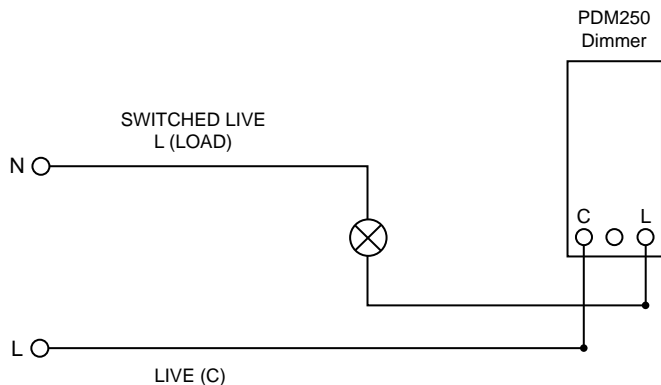

WIRING DIAGRAM - MULTIPLE PDM250 DIMMER SWITCHES

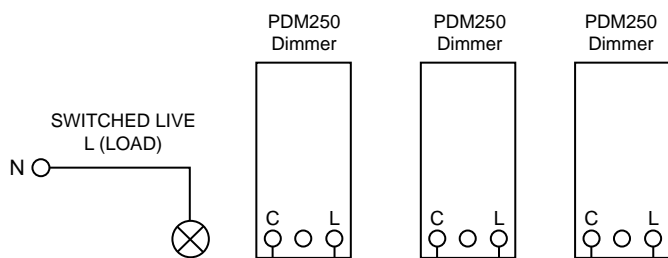

OPERATING INSTRUCTIONS

MULTI-WAY DIMMING - FUNCTIONALITY

Multiple PDM250 dimmers in a connected set (connected in parallel), will all share the same settings and dimming position, including high and low settings. Because of this, it is important to only use the same luminaire type, per set of dimmers to avoid any mismatch between high and low settings.

It is only necessary to perform any hi/low or reset button sequences on one of the PDM250 dimmers connected in a set, this must be performed only after all dimmers on the circuit have been connected together.

IMPORTANT NOTE: The PDM250 only works with other PDM250s and does not work in conjunction with any other type of dimmer switch.

A reset sequence must be performed if dimmers are added or subtracted from the circuit, or luminaire type is changed, and then hi/low setup repeated.

ON OFF & DIMMING FUNCTION

Dimmer switch is activated by pressing the dimmer shaft only, dimming function by rotating the dimmer shaft only.

REAR PANEL PRESS BUTTON - DIMMER SETUP SEQUENCES

Setting the Minimum Level (Anywhere below 50% of range)

1. Whilst on, slowly adjust dimmer to your desired minimum brightness.
2. Push the rear setup button 3 times within 2 seconds.
3. The LEDs will step up and down in brightness once to confirm the setting has been saved.

Setting the Maximum Level (Anywhere above 50% of range)

1. Whilst on, slowly adjust dimmer to your desired maximum brightness.
2. Push the rear setup button 5 times within 3 seconds.
3. The LEDs will step up and down in brightness once to confirm the setting has been saved.

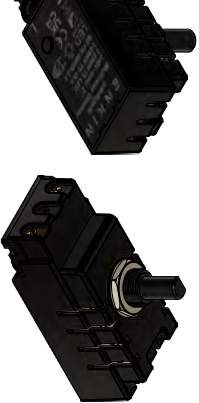
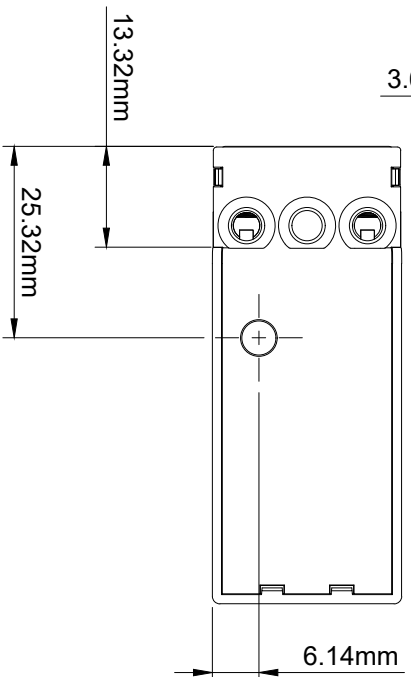
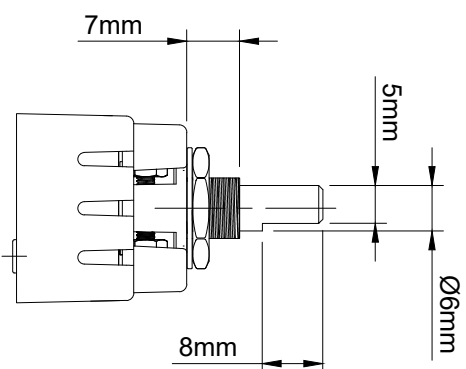
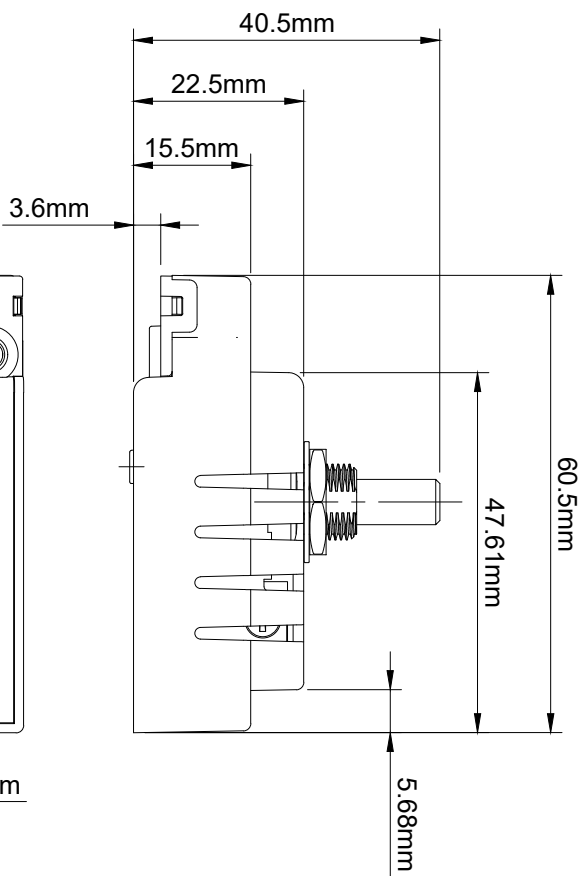
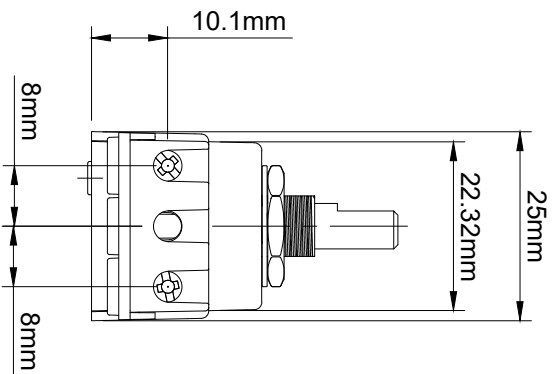
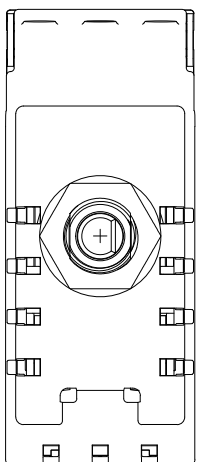

PDM250 - Intelligent Multi-way Dimmer

